

**THE EFFECTIVENESS OF USING MORPHOLOGICAL STUDY METHOD IN
TEACHING SPECIALIZED SUBJECTS**

Davronova Mukhayyo Usubjanovna

Namangan Engineering construction institute , senior lecturer E-mail:m_davronova@gmail.com

Qozaqova Munajat Sharifjanovna

Doctoral student of Namangan Engineering and Construction Institute

Abstract: The issue of formation of technical creativity in higher educational institutions is multifaceted, it includes such an important pedagogical task as identification of effective ways of preparing students for creative activity and the appropriate selection of content, as well as the development of specific methods and means of generalizing technical creativity in the educational process the social and professional President of the Republic of Uzbekistan Sh. Mirziyoyev, October 8, 2019 in the decree № PD-5847 on approval of the concept of development system of the System modernization of higher education, development of social and economic sectors based on advanced educational technologies, raising the process of training it is defined on the development OEMs. In this article highlights about methods of development of design competents in future specialists.

Keywords: knowledge, creativity, pedagogical tasks, effectiveness of education, innovative technologies, pedagogical process, innovations, professionals.

Introduction

Therefore, we need to pay more attention to the creative work of future professionals who can meet the requirements of international standards. One of the most pressing issues today is the application of new methods of imparting knowledge, skills and abilities to students, the creation and provision of aids to them in all areas of education, in line with modern requirements. Overcoming today's problems requires the teacher to use innovative technologies in the classroom to increase the effectiveness of education, so there is an opportunity to introduce innovative pedagogical technologies in all disciplines and on this basis to increase student achievement.

In the organization of pedagogical processes, pedagogical innovations play an important role in conducting experiments and practical training in all disciplines. Innovative technologies should be widely used in experimental work. Innovative technologies are the pedagogical process, innovations in teacher and student activities, the introduction of problematic questions in the examination of the knowledge of future professionals, carried out through the interaction of teacher and student.

The foundation of innovative technology is seen in the design of the learning process in advance so that the teacher and the student can achieve the goal they have set for themselves. It is advisable for the teacher to design the process of performing the next problematic experiment so that he or she can see the results in each experiment. In this case, it is important for the teacher to create a technological map of the experimental work in the next lesson, because the technological map created by the teacher for each experimental work allows you to approach the content, understand, plan all stages from the beginning of the learning process. In particular, the technological map, if created based on the needs and needs of the student, brings the student to the center of the process of practical work as an individual and allows to increase the effectiveness of teaching.

In order to create such a technological map in the conduct of experimental work in the specialty disciplines, the teacher must be aware of technology, psychology, pedagogy, private

methodology, modern pedagogical and information technologies, as well as a thorough knowledge of teaching and learning methods. The use of pedagogical technologies in the learning process has a positive impact on the content of education and the student's ability to think creatively.

Therefore, we use the method of morphological analysis proposed by the Swiss astronomer Fritsem Zwicky in the teaching of specialty sciences. This method is the first method that takes a systematic approach to the field of invention.

Morphological analysis (method of morphological analysis) is a method of solving problems based on the selection of possible solutions for individual parts of the problem (called morphological features that characterize the device) and their subsequent systematic acquisition (combination). In order to perform morphological analysis, it is necessary to clearly formulate the problem for the system under consideration. As a result, the answer to the general question is given by searching for all the options of specific solutions, regardless of whether there is only one specific system in the original problem.

The essence of this method is as follows:

- in the technical system, several of the structural or functional morphological features characteristic of it are distinguished;;
- for each character a list of its possible options, alternatives is made;
- the characters can be placed in the form of tables called morphological boxes or matrices;
- this allows the time spent on research to be predetermined because by generating different options from the list of characters created, a new solution to the problem can also be identified.

Therefore, the method of morphological analysis is used more in the search for the field of possible solutions, rather than in search of any single solution. We will consider the essence of the method of morphological analysis in the teaching of technical sciences to future specialists in the example of vehicle creation. Suppose we are faced with the problem of creating a lunar eclipse. Lunahod is a vehicle designed to move on the lunar surface, remotely control the lunar rover and serves as a self-propelled robot

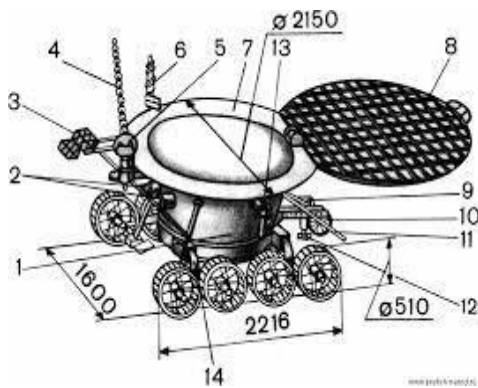

We first define the parameters that depend on the solution of the problem and compile a list of them.

Morphological box

| | | Features | | | | |
|---|---------------|--------------------|-----------------|-----------------|----------------|---|
| | | 1 | 2 | 3 | 4 | 5 |
| A | <i>Engine</i> | <i>electricity</i> | <i>chemical</i> | <i>reactive</i> | <i>nuclear</i> | |

| | | | | | | |
|---|-----------------------------|------------------|-------------------------|-----------------------|---------------|----------|
| | | | | | <i>engine</i> | |
| B | <i>Mechanisms of motion</i> | <i>wheeled</i> | <i>caterpillars</i> | <i>stepping stone</i> | <i>auger</i> | |
| C | <i>Cabin</i> | <i>hermetic</i> | <i>nohermetic</i> | <i>3</i> | <i>4</i> | <i>5</i> |
| D | <i>Management</i> | <i>via radio</i> | <i>with the program</i> | <i>using EC</i> | | |
| | | | | | | |

Based on the list in the morphological box, we create a matrix:

A1 A2 A3 A4
B1 B2 B3 B4

C1 C2

D1 D2 D3

This structured matrix is a definite form of writing possible solutions. Each concrete variant of the construction is determined by the collection of elements of different series. Thus, the morphological analysis revealed that in the variant A1, B2, C2, D2, ... lunakhod transport is controlled by electric motor, caterpillar and cabin non-hermetic and software.

The number of possible options is equal to the product of the number of elements in each row.

The number of possible options in the example we are looking at:

$$H=4 \times 4 \times 2 \times 3=96 \text{ за менз}$$

Once the matrix has been constructed, it is time to move on to determining the functional evaluation of the solution options. This is a labor-intensive and important issue. Given the different combinations of these elements, prospective professionals can get a great combination of all possible solutions, including the most unexpected ones

A matrix is a symbolic form of describing solutions. Displaying one of the elements in each row of the matrix gives an idea of all the possible design schemes of the lunakhod. This set of elements represents a possible variant of the original problem. Given the different combinations of these elements, you can get a great combination of all possible solutions, including the most unexpected ones [3].

Thus, the morphological matrix for chemically fueled jet engines built by F. Tsvikki included 576 possible solutions. The highest step of the method is to evaluate the illuminations resulting from the morphological matrix structure. Using this method in the teaching of specialty subjects, future professionals should identify the problem parameters that need to be solved on the issues of the given option and make a list of them. He must then construct an issue matrix and determine the number of possible options. The names of the identified parameters and their list are recorded in Table 1.

1-Table

| <i>The name of the problem to be solved</i> | <i>Object parameter name and list</i> |
|---|---------------------------------------|
| | |
| | |

Issue options

2-Table

| <i>Variant numbers</i> | <i>The name of the matter (object)</i> |
|------------------------|--|
| 1 | <i>Robot-Excavator</i> |
| 2 | <i>Drone</i> |
| 3 | <i>Melon harvesting machine</i> |
| 4 | <i>Cotton picking machine</i> |
| 5 | <i>Carrot slicer</i> |
| 6 | <i>A robotic machine that works during a fire</i> |
| 7 | <i>A robotic machine that rescues overturned houses</i> |
| 8 | <i>A robotic machine performing underwater rescue operations</i> |
| 9 | <i>A robotic machine that rescues those trapped underground</i> |

In particular, by applying the above method of morphological analysis in practice and practical

training, future professionals will develop a level of professional and creative training, increase creativity and creative thinking, develop design competencies, resulting in increased educational effectiveness.

References :

1. М.У.Давронова Техник ижодкорлик ва дизайн ўқув қўлланма -. Наманган ш. Наманган нашр -2020й.
2. ЁКУТХОН Н., Абдуллаева Н., Мухайё Д. Перспективы адаптации выпускников профессиональных колледжей на производственных предприятиях //European research. – 2016. –
3. №. 3 (14).
4. Najmiddinova Yo. R. Conditions of Forming Professional Abilities and Skills on Competence Approach among Colleges Students // Eastern European Scientific Journal. - Germany, 2018. -№4. - P.196- 199.
5. Нажмиддинова Ё.Р., Давронова М.У. Бўлажак муҳандис-техникларда касбий тарбия муаммоси. – “Техника ва технологик фанлар соҳаларининг инновацион масалалари” мавзусидаги халқаро илмий-техник анжумани. ТДТУТФ -2020 йил. 24-бет.

6. Najmiddinova Yo. R., Inamov D. D., Davronov M. U., Inamiddinova D. k. Methodology of the formation of general vocational training in students of higher educational institutions on the basis of competency approach // *Palarch's journal of archaeology of Egypt / Egyptology, pjaee*, 17(6)(2020). – 3663-3679 page.
<http://www.palarch.nl/index.php/jae/article/view/1482>
7. [Aspects of methods and forms of teaching technical subjects](#). dm usubjanovna - galaxy international interdisciplinary research ..., 2022 - giirj.com. galaxy international interdisciplinary research journal (giirj) issn (e):2347-6915 vol. 10, issue 2, feb. (2022) 743 aspects of page 1 galaxy international ...
8. Бўлажак мутахассисларни мутахассислик фанларини ўқитишда лойиҳалаш компетенцияларини шакллантириш зарурияти. НамДу Илмий ахборотномаси, 2021 й. 667-бет.
9. Бўлажак мутахассисларда умумқасбий ва ихтисослик фанлари бўйича ривожлантириш интеграциялашган билим ва кўникмаларни асосида лойиҳалаш компетенцияларини ривожлантириш. НамДу Илмий ахборотномаси, 06.2022 й. 1004-бет.
10. Sharifjanovna, Q. M. (2021). Perpendicularity of a Straight Line to a Plane and a Plane to a Plane. *International Journal of Innovative Analyses and Emerging Technology*, 1(5), 70-71.
11. Abduraximovich, U. M., & Sharifjanovna, Q. M. (2021). Methods of Using Graphic Programs in the Lessons of Descriptive Geometry. *International Journal of Discoveries and Innovations in Applied Sciences*, 1(6), 149-152.
12. Sharifjanovna, Q. M. (2022). METHODS OF USING FINE ARTS IN THE PROCESS OF DEVELOPING THE PROFESSIONAL COMPETENCIES OF FUTURE ARCHITECTS. *INTERNATIONAL JOURNAL OF RESEARCH IN COMMERCE, IT, ENGINEERING AND SOCIAL SCIENCES ISSN: 2349-7793 Impact Factor: 6.876*, 16(5), 49-51.
13. Комилов, С., & Козокова, М. (2015). Разработка вычислительного алгоритма решения гидродинамических задач управления процессами ПВ в неоднородных средах при условии использования этажной системы разработки. *Молодой ученый*, (11), 324-328.
14. Mallaboyev, N. M., Sharifjanovna, Q. M., & Nodirbek, M. (2022, May). INTERACTION BETWEEN INFORMATION COMPLEXES IN ECONOMIC SPHERES. In *Conference Zone* (pp. 250-253).
15. Sharifjanovna, Q. M. (2022). THE ROLE AND FUNCTION OF INFORMATION AND COMMUNICATION TECHNOLOGIES IN THE DIGITAL ECONOMY. *ASIA PACIFIC JOURNAL OF MARKETING & MANAGEMENT REVIEW ISSN: 2319-2836 Impact Factor: 7.603*, 11(05), 19-21.
16. Mallaboyev, N. M., Sharifjanovna, Q. M., Muxammadjon, Q., & Shukurullo, C. (2022, May). INFORMATION SECURITY ISSUES. In *Conference Zone* (pp. 241-245).
17. Mallaboyev, N. M., & Sharifjanovna, Q. M. Elmurod G 'ayratjon o 'g, U., & Najmiddin Ulug 'bek o 'g, T. (2022, May). TRENDS IN THE SPEED OF INTERNATIONAL INFORMATION NETWORKS. In *Conference Zone* (pp. 246-249).
18. Mallaboyev, N. M., Sharifjanovna, Q. M., Elmurod G 'ayratjon o 'g, U., & Najmiddin Ulug 'bek o 'g, T. (2022, May). TRENDS IN THE SPEED OF INTERNATIONAL INFORMATION NETWORKS. In *Conference Zone* (pp. 246-249).